

Please check the examination details below before entering your candidate information

Candidate surname

Other names

**Pearson Edexcel
Functional Skills**

Centre Number

Candidate Number

Set 7

Time: 1 hour 30 minutes

Paper Reference **PMAT2/C07**

Mathematics

Level 2

Section B (Calculator)



You must have:

Pen, calculator, HB pencil, eraser, ruler graduated in cm and mm, protractor, pair of compasses. Tracing paper may be used.

Total Marks

My signature confirms that I will not discuss the content of the test with anyone.

Signature: _____

Instructions

- Use **black** ink or ball-point pen.
- **Fill in the boxes** at the top of this page with your name, centre number and candidate number.
- Sign the declaration.
- Answer **all** questions.
- Write your final answers in the boxes provided.
- Answer the questions in the spaces provided – *there may be more space than you need.*
- You **must** show clearly how you get your answers in the spaces provided. Marks will be awarded for your working out.
- Check your working and answers at each stage.
- Diagrams are **not** accurately drawn, unless otherwise indicated.
- **Calculators may be used.**
- If your calculator does not have a π button take the value of π to be 3.14

Information

- The total mark for this section is 48.
- The total mark for this paper is 64.
- The marks for **each** question are shown in brackets
– *use this as a guide as to how much time to spend on each question.*
- This sign shows where marks will be awarded for showing your checks.

Advice

- Read each question carefully before you start to answer it.
- Check your answers if you have time at the end.

Turn over ►

P68467A

©2021 Pearson Education Ltd.

1/1/1/1



Pearson

SECTION B

Answer ALL questions. Write your answers in the spaces provided.

1 Here is a formula.

$$K = \frac{3(U + 7.15)}{V}$$

Work out the value of K when $U = 2.9$ and $V = 6$

(3)

(Total for Question 1 is 3 marks)

DO NOT WRITE IN THIS AREA

DO NOT WRITE IN THIS AREA

DO NOT WRITE IN THIS AREA

DO NOT WRITE IN THIS AREA

DO NOT WRITE IN THIS AREA

DO NOT WRITE IN THIS AREA



2 Shona and Erica are gymnasts.

Here are the scores Shona got in the last 7 competitions.

12.9	14.3	14.1	13.0	13.2	13.9	13.1
------	------	------	------	------	------	------

Erica only took part in six of these competitions and had a

- mean score of 13.4
- median score of 13.3
- range of scores of 1.5

Shona thinks on average her scores were better than Erica's scores.
Erica does not agree.

Explain how Shona and Erica could both be correct.
You **must** show your working.

(3)

(Total for Question 2 is 3 marks)



- 3 Archie puts an advert for his company online.
He has to pay £0.85 each time someone clicks on his advert.

At the end of week 1 Archie pays £650.25 for the total number of clicks on his advert.

Archie estimates that each week the total number of clicks on his advert will increase by 20% on the previous week.

Archie thinks that in week 3 more than 1000 people will click on his advert.

Is he correct?
Show why you think this.

(4)

(Total for Question 3 is 4 marks)

DO NOT WRITE IN THIS AREA

DO NOT WRITE IN THIS AREA

DO NOT WRITE IN THIS AREA

DO NOT WRITE IN THIS AREA

DO NOT WRITE IN THIS AREA

DO NOT WRITE IN THIS AREA



4 The scatter diagram shows information about the age of patients and the waiting time for these patients to get an appointment.

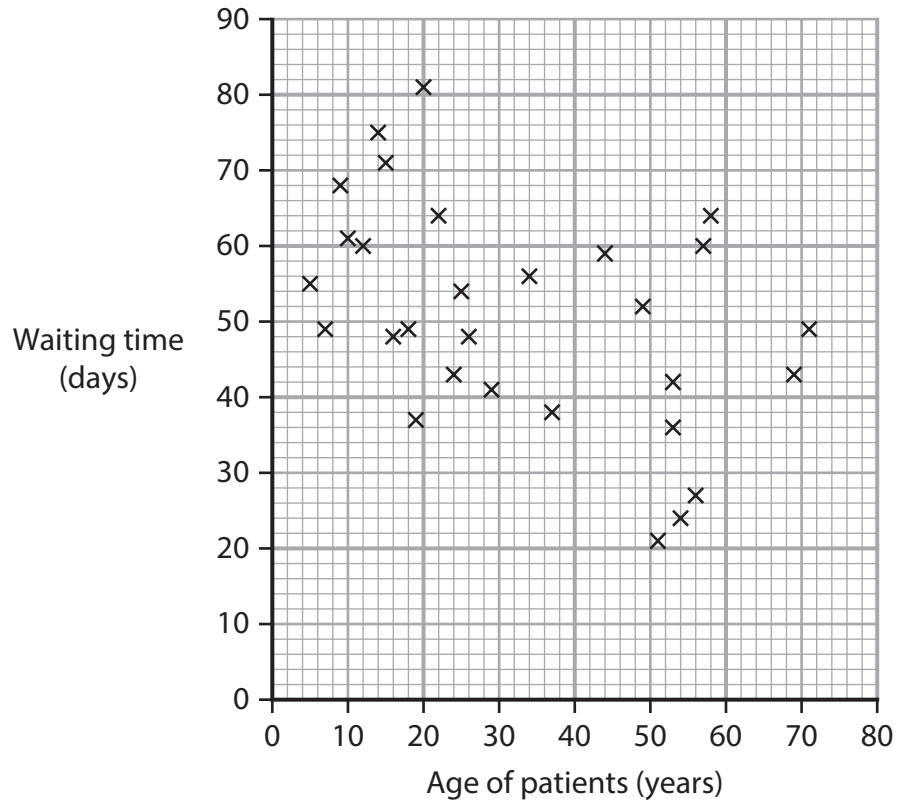

(a) Describe the relationship between the age of patients and the waiting time.

(1)

(b) Work out the fraction of patients aged over 50 who had a waiting time greater than 30 days.

(2)

(Total for Question 4 is 3 marks)



P 6 8 4 6 7 A 0 5 2 0

5 Kelly works in a grocery shop.

She wants to order 120 chocolate eggs.

Kelly finds this offer.

box of 30 chocolate eggs
normal price £65
now 16% off the normal price

She thinks she can buy 120 chocolate eggs for less than £200 with this offer.

(a) Is Kelly correct?
Show why you think this.

(4)

DO NOT WRITE IN THIS AREA

DO NOT WRITE IN THIS AREA

DO NOT WRITE IN THIS AREA

DO NOT WRITE IN THIS AREA

DO NOT WRITE IN THIS AREA

DO NOT WRITE IN THIS AREA



DO NOT WRITE IN THIS AREA

DO NOT WRITE IN THIS AREA

DO NOT WRITE IN THIS AREA

DO NOT WRITE IN THIS AREA

DO NOT WRITE IN THIS AREA

DO NOT WRITE IN THIS AREA



(b) Use a reverse calculation to show a check of your answer.

(1)

(Total for Question 5 is 5 marks)



6 Abdul is an apprentice architect.
He has this diagram of a building.

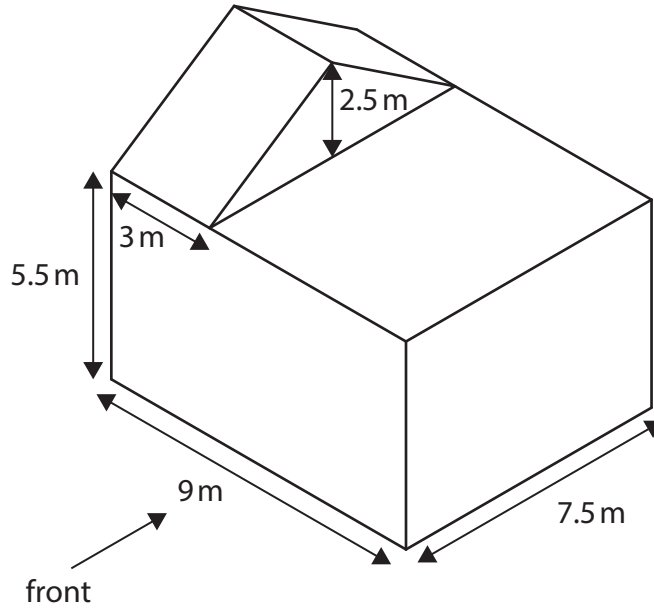

Draw the front elevation of this building on the centimetre grid.
Use a scale of 1 : 100

(3)

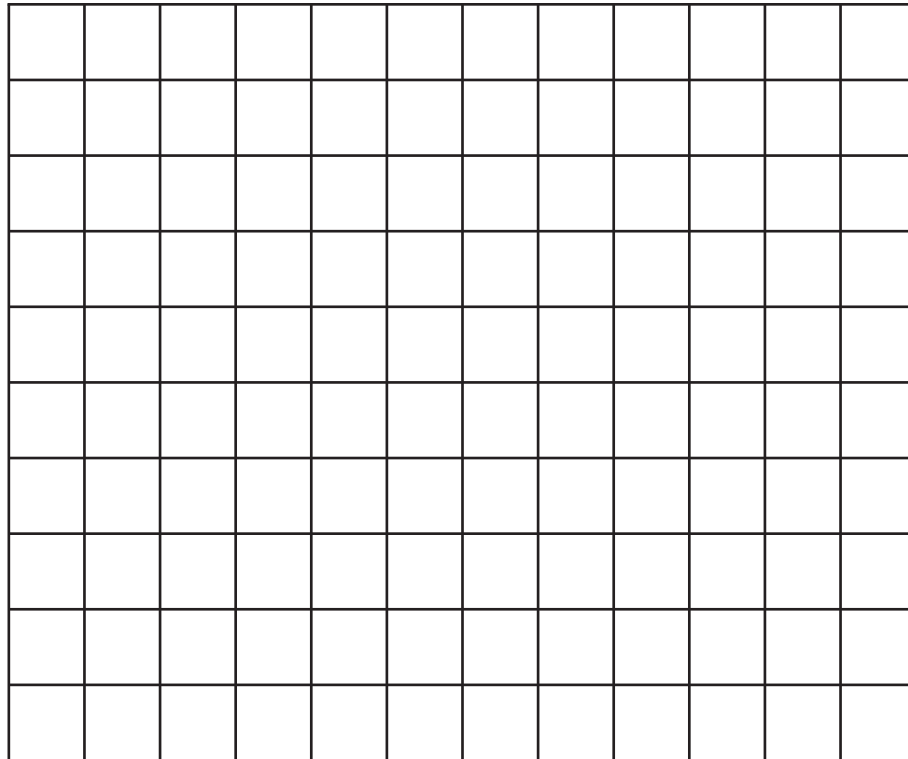

(Total for Question 6 is 3 marks)

DO NOT WRITE IN THIS AREA

DO NOT WRITE IN THIS AREA

DO NOT WRITE IN THIS AREA

DO NOT WRITE IN THIS AREA

DO NOT WRITE IN THIS AREA

DO NOT WRITE IN THIS AREA



7 The tree diagram shows the probability that an item of clothing selected at random is

- a skirt or a dress
- long or short.

(a) Complete the probability tree diagram.

(2)

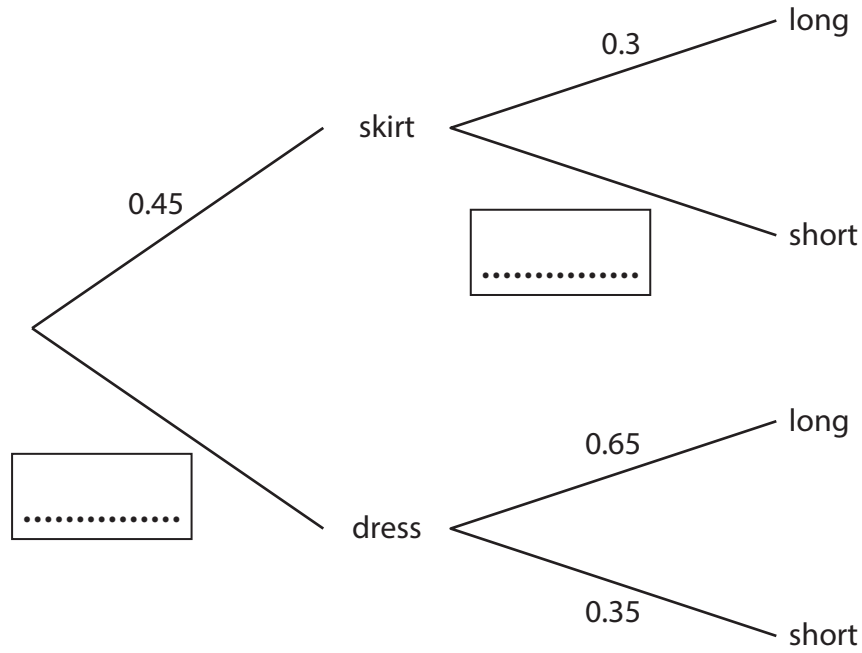

An item of clothing is chosen at random.

(b) Work out the probability that this item is a long skirt.

(2)

(Total for Question 7 is 4 marks)



8 Takeshi is the manager at a laboratory.

The table shows information about the number of tests done at the laboratory each day in April.

Number of tests	Frequency (days)
1 to 10	8
11 to 20	14
21 to 30	5
31 to 40	3
Total	30

Takeshi expects the mean number of tests done each day in May to be 12.5% greater than the estimated mean number of tests done each day in April.

The laboratory is open for 31 days in May.

Each test brings an income of £130 for the laboratory.

Work out the expected income for the laboratory in May.
You **must** show your working.

(6)

DO NOT WRITE IN THIS AREA

DO NOT WRITE IN THIS AREA

DO NOT WRITE IN THIS AREA

DO NOT WRITE IN THIS AREA

DO NOT WRITE IN THIS AREA

DO NOT WRITE IN THIS AREA



DO NOT WRITE IN THIS AREA

DO NOT WRITE IN THIS AREA

DO NOT WRITE IN THIS AREA

DO NOT WRITE IN THIS AREA

DO NOT WRITE IN THIS AREA

DO NOT WRITE IN THIS AREA

£

(Total for Question 8 is 6 marks)



9 Jasper organises large events.

Last week 23 workers took 4 hours to build a stage for a concert.

Next week Jasper wants to hire workers to build the same stage in 3 hours.

Work out the minimum number of workers needed to build the stage in 3 hours.

(3)

(Total for Question 9 is 3 marks)

DO NOT WRITE IN THIS AREA

DO NOT WRITE IN THIS AREA

DO NOT WRITE IN THIS AREA

DO NOT WRITE IN THIS AREA

DO NOT WRITE IN THIS AREA

DO NOT WRITE IN THIS AREA



10 Here is a coordinate grid.

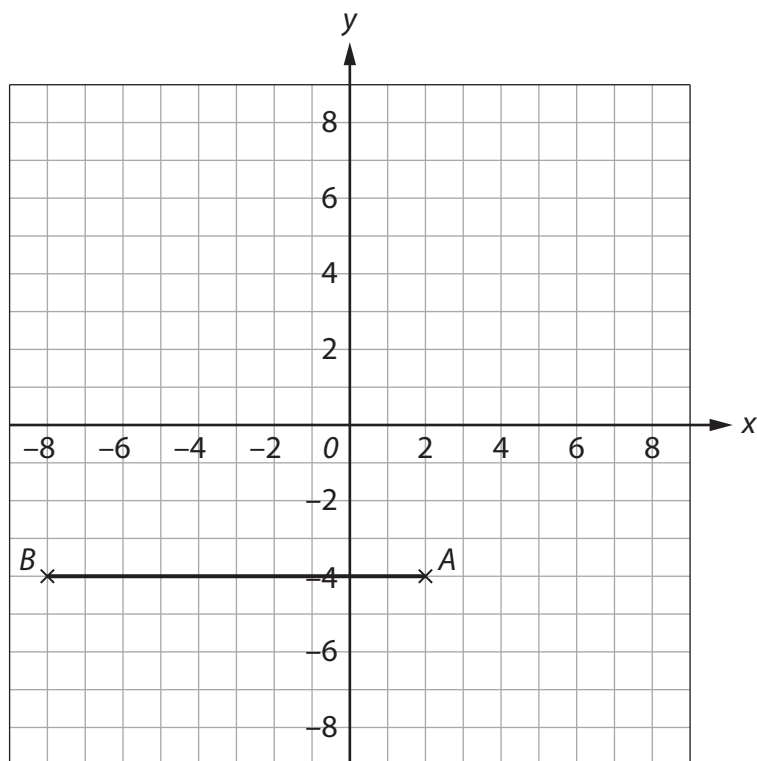

(a) Plot and label the point C at $(-3, 6)$

(1)

Sylvie wants to draw a trapezium $ABCD$ on the grid.

She will use the straight line AB as the base of the trapezium.

Sylvie wants the trapezium to have two right angles.

(b) Plot and label a point D on the grid to complete the trapezium for Sylvie.

(2)

(Total for Question 10 is 3 marks)



11 Vicky works in a park.

She needs to put edging around a lawn in the park.

The diagram shows the dimensions of the lawn.
The lawn is made up of rectangles.

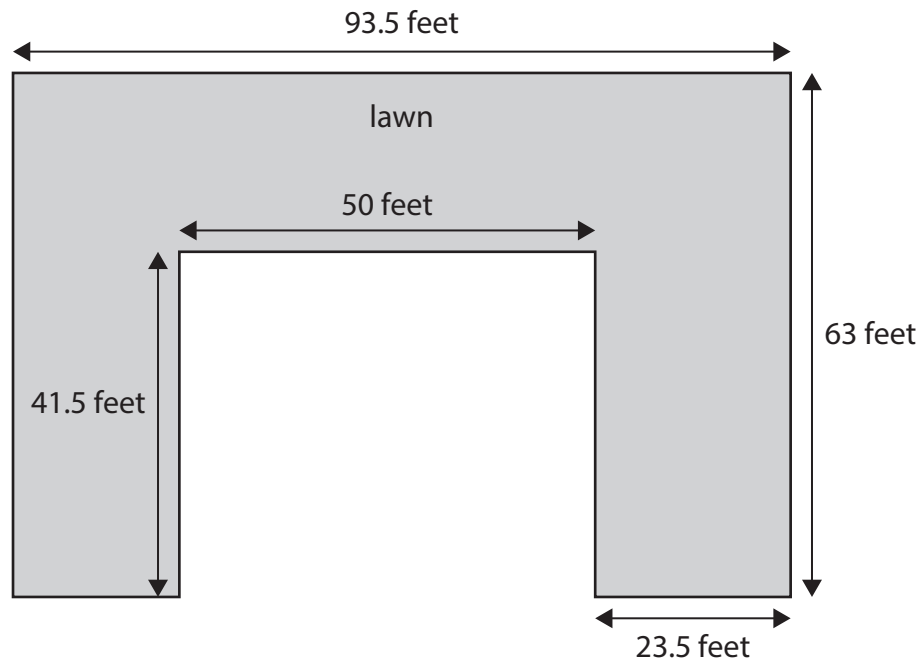

Vicky will buy edging in 5 metre lengths.
She can cut and join the lengths of edging.
She knows that 1 metre is 3.3 feet.

Each length of edging costs £38.99
Vicky has £1000 to buy the edging.

Does Vicky have enough money to buy all the edging she needs?

(5)

DO NOT WRITE IN THIS AREA

DO NOT WRITE IN THIS AREA

DO NOT WRITE IN THIS AREA

DO NOT WRITE IN THIS AREA

DO NOT WRITE IN THIS AREA

DO NOT WRITE IN THIS AREA



DO NOT WRITE IN THIS AREA

DO NOT WRITE IN THIS AREA

DO NOT WRITE IN THIS AREA

DO NOT WRITE IN THIS AREA

DO NOT WRITE IN THIS AREA

DO NOT WRITE IN THIS AREA

[Large empty rectangular area for writing]

[Small empty rectangular box]

(Total for Question 11 is 5 marks)



12

(a) Write as a number

seven million four hundred and thirty thousand nine hundred.

(1)

Dorothy reads an article about a talent show.

The article states that 17 424 people applied to enter the show last year.
Each person that applied was either a singer or a dancer.

The ratio of the number of singers to the number of dancers was 3 : 5

This year 19 500 people applied to enter the show.
39% of these people were singers.

Dorothy thinks that at least 1200 more singers applied to enter the show this year
than last year.

(b) Is she correct?

Show why you think this.

(5)

DO NOT WRITE IN THIS AREA

DO NOT WRITE IN THIS AREA

DO NOT WRITE IN THIS AREA

DO NOT WRITE IN THIS AREA

DO NOT WRITE IN THIS AREA

DO NOT WRITE IN THIS AREA



DO NOT WRITE IN THIS AREA

DO NOT WRITE IN THIS AREA

DO NOT WRITE IN THIS AREA

DO NOT WRITE IN THIS AREA

DO NOT WRITE IN THIS AREA

DO NOT WRITE IN THIS AREA

(Total for Question 12 is 6 marks)

TOTAL FOR SECTION B IS 48 MARKS
TOTAL FOR PAPER IS 64 MARKS





DO NOT WRITE IN THIS AREA

DO NOT WRITE IN THIS AREA

DO NOT WRITE IN THIS AREA

DO NOT WRITE IN THIS AREA

DO NOT WRITE IN THIS AREA

DO NOT WRITE IN THIS AREA

BLANK PAGE



DO NOT WRITE IN THIS AREA

DO NOT WRITE IN THIS AREA

DO NOT WRITE IN THIS AREA

DO NOT WRITE IN THIS AREA

DO NOT WRITE IN THIS AREA

DO NOT WRITE IN THIS AREA

BLANK PAGE



P 6 8 4 6 7 A 0 1 9 2 0

DO NOT WRITE IN THIS AREA

DO NOT WRITE IN THIS AREA

DO NOT WRITE IN THIS AREA

BLANK PAGE

